

Cargo Boxes/Containers

Battery Box

cargo carrying unit

CARGO CARRYING LOGISTIC SOLUTIONS FOR THE 21ST CENTURY OILFIELD

Rental, Consignment, Lease Programs plus Purchase of Standard or Custom Built Cargo Carrying Units

KEY BENEFITS

Battery Box for safe handling and storage of batteries where caustic elements might be present.

Built in safety features, with industry standard load and rigging certifications.

KEY FEATURES

- GPS equipped and online tracking on all rental equipment
- Hot dip galvanized
- Standard shipped with a 2 or 4-part rigging /sling set
- Sling documentation available on request
- Domestic safety anchor shackles supplied with sling set.
- All sling set load capacities based on a 60° sling angle
- Stamped engineers structural analysis cover letter available
- Certified 3rd-party load test and non-destructive pad eye test (MPI / Dye Penetration).
- Engineered to Meet or Exceed API RP 2A and BHP requirements
- Conforms to Shell Exploration and Production Co (SEPCo) Document OPS 0055, latest edition

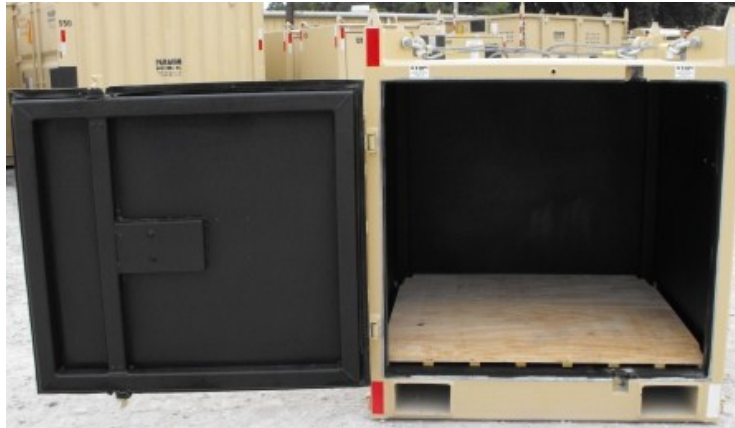

Battery Box

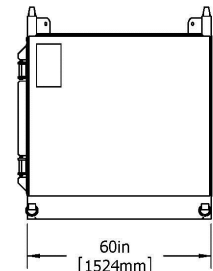
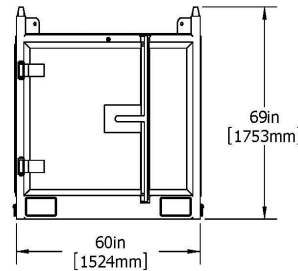
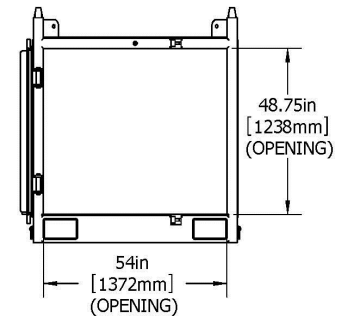

Specifications

Tare	SWL/Payload	Max Gross	Max Forklift	Test Weight
2,500 lbs	10,000 lbs	12,500 lbs	12,500 lbs	25,000 lbs

Inside Dimension	Outside Dimension	Cu. Ft.
54"Lx54"wx49"h	5'-1/2"Lx5'-1/4"wx 5'9"h	100

OPTIONS

Custom Engineered Design/Build Configurations for Unique Needs

Shackle Size	Sling Size	45° Sling Capacity	60° Sling Capacity
3/4" SAS	5/8"x5'-9"x4-part	11 Ton	14 Ton

