

PARAGON

Eight Drum w/Integral Tank



Specifications

Tare	SWL/Payload	Max Gross	Max Forklift	Test Weight
2,500 lbs	15,500 lbs	18,000 lbs	18,000 lbs	36,000 lbs

Inside Dimension	Outside Dimension	Cu. Ft.
8-55 gal. Drums with 198 gal. spill tank	123"Lx51"Wx48"H	N/A

Shackle Size	Sling Size	45° Sling Capacity	60° Sling Capacity
5/8" SAS	3/4"x10'-8"x4-part	11 Ton	14 Ton

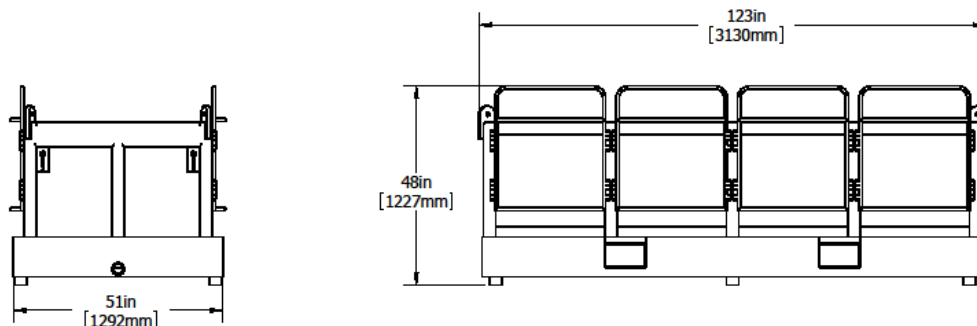

Paragon Industries, Inc.
2025 Railroad Avenue
Morgan City, LA 70380

www.paragonind.net

Phone: 985.384.6980
Toll Free: 800.391.9644
Fax: 985.384.6985