

PARAGON

Battery Box



Specifications

Tare	SWL/Payload	Max Gross	Max Forklift	Test Weight
2,500 lbs	10,000 lbs	12,500 lbs	12,500 lbs	25,000 lbs

Inside Dimension	Outside Dimension	Cu. Ft.
54"Lx54"wx49"h	5'-1/2"Lx5'-1/4"wx 5'9"h	100

Shackle Size	Sling Size	45° Sling Capacity	60° Sling Capacity
3/4" SAS	5/8"x5'-9"x4-part	11 Ton	14 Ton

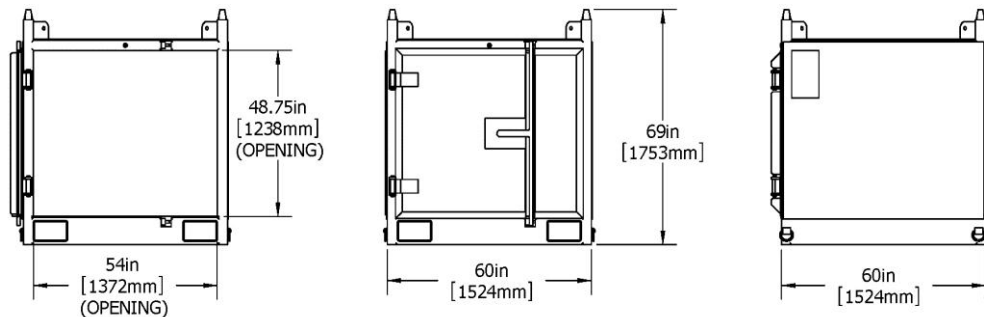

Paragon Industries, Inc.
2025 Railroad Avenue
Morgan City, LA 70380

www.paragonind.net

Phone: 985.384.6980
Toll Free: 800.391.9644
Fax: 985.384.6985